



Let's build a Wallbed together!

www.murphywallbedsystems.com

studio™

Universal Desk/Table for All
Sizes of Alpha Panel Wall
Beds

Assembly Instructions

**** LIFETIME WARRANTY ****

Designed to Exceed International ISO 9002
Standards for Residential Specifications

- Patent Pending -

Exploded Assembly

Hinges and Hinge Clips to Back and Bed Face Panel

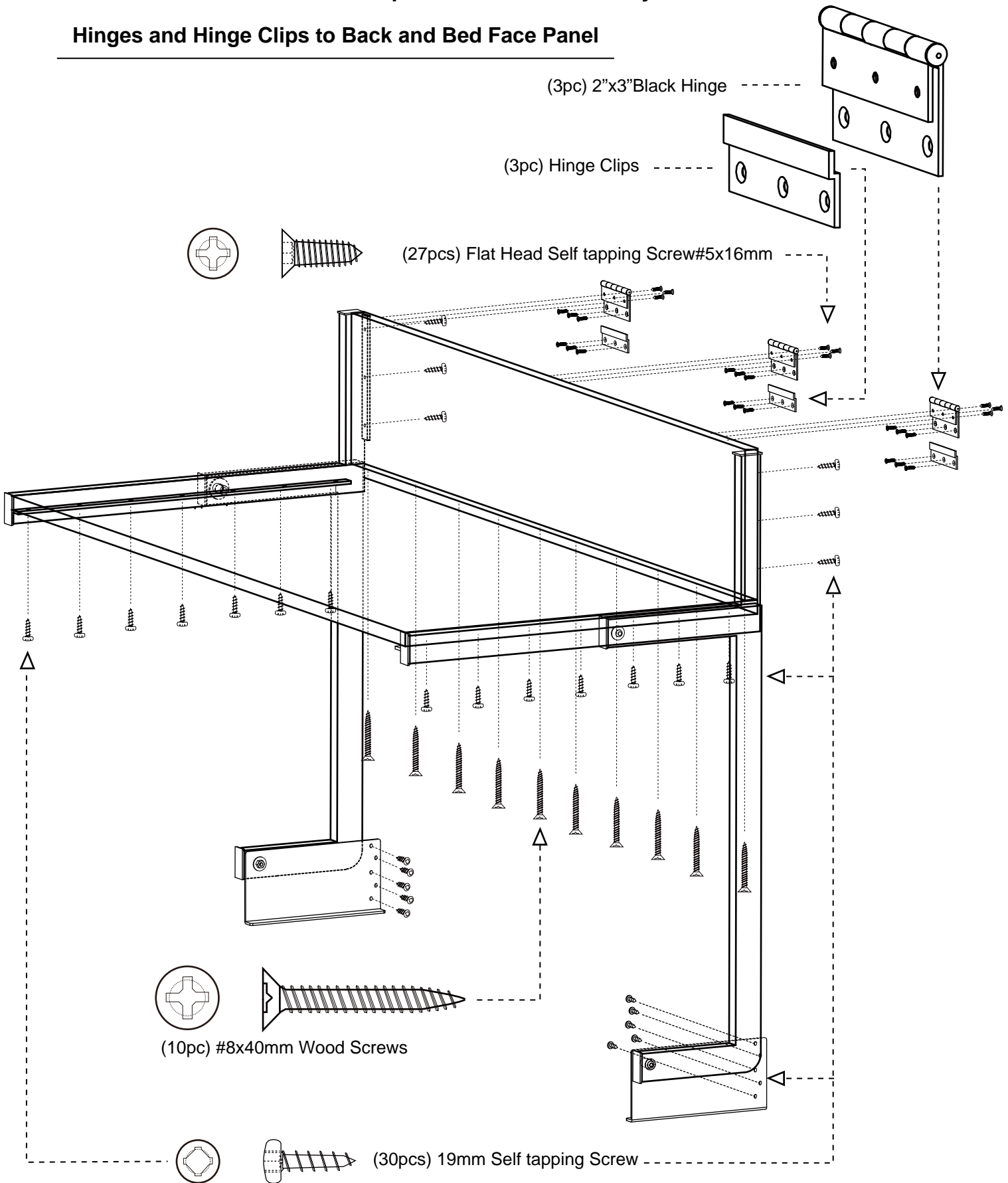

Pre Assembled KIT

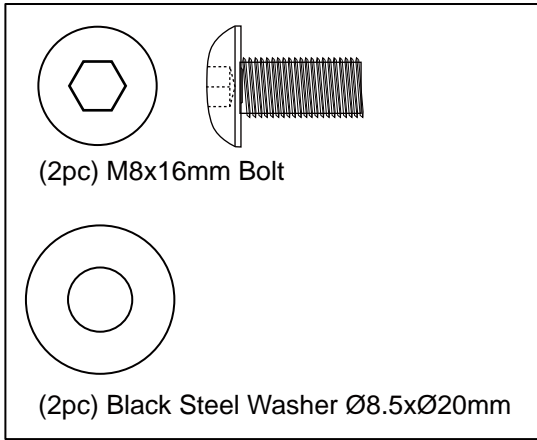

Legs to Upper Brackets

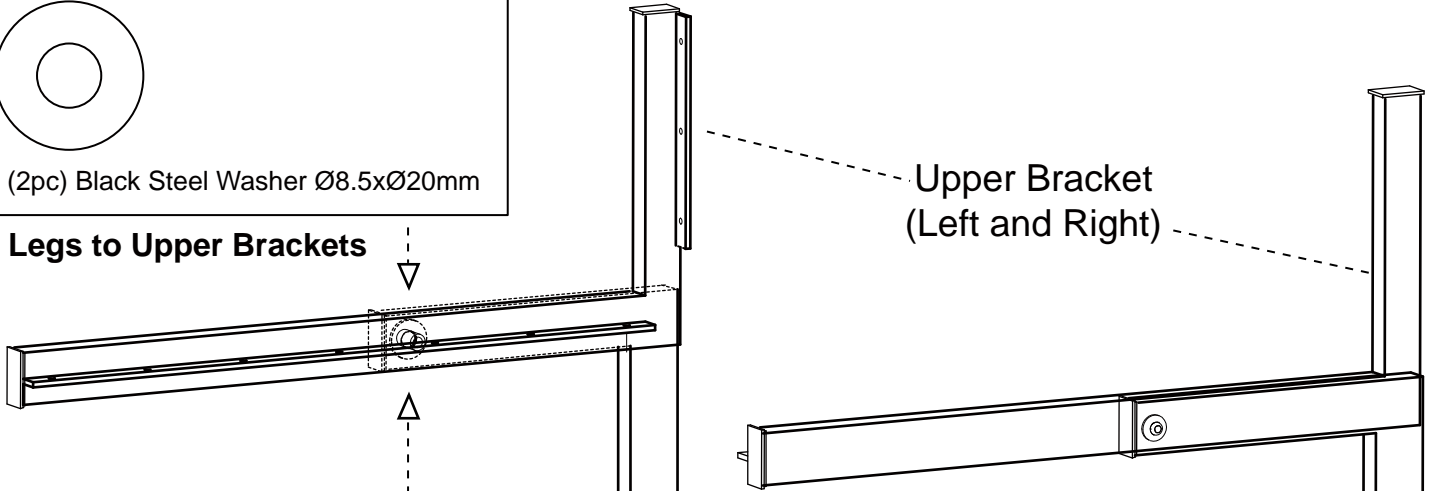

Washers stop friction between
Legs, Upper and Lower Brackets

(4pc) Black Nylon Washer $\text{Ø}13 \times \text{Ø}30\text{mm}$

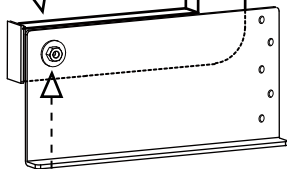
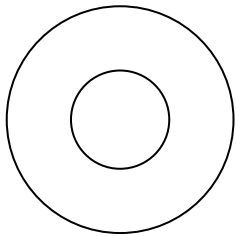

Pivot Bracket (Left and Right)

Legs to Pivot Brackets

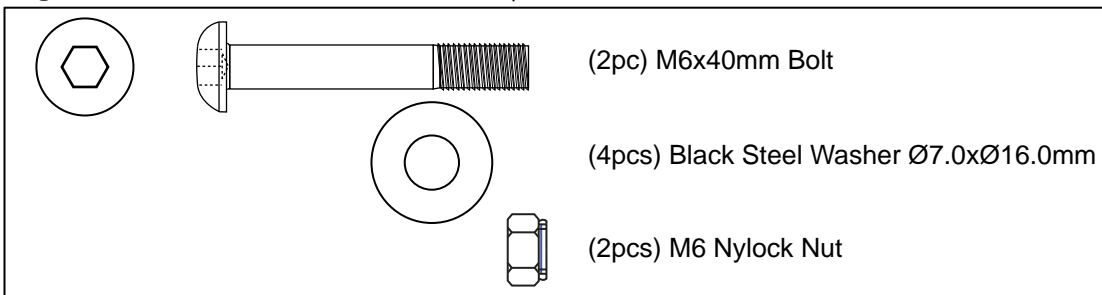

Project Start-Up

1. Familiarize yourself with all of the components in the Studio Desk/Table mechanism cartons, as well as thoroughly study this manual so you may plan the steps required to complete this project.
2. Study all illustrations and plan drawings. Make sure that the space available in the room is adequate for the specified dimensions in both the open and closed positions.

NOTE: If your wall bed cabinetry is made using 16mm board. Desk Leg packers will be required to pack out the Pivot Brackets. This will square up the desk leg with the cabinetry.

Steps to Complete the Project

STEP 1: Prepare Desk Top and Back

1. Determine the length of your desk.
 - All Desks are 560mm in Depth .
 - All Backs are 216mm in Height
 - Length of Desk and Back assembly is always 38mm less than the measured distance between the vertical Cabinet side walls. E.g. The ALPHA bed Queen cabinet is 1626mm between the vertical cabinet side walls therefore the Desk and Back will be 1588mm in width.
 - Desk leg packers need to be a minimum 5mm thickness cut size is: 100mm L x 45mm W
2. Edge-band the two long edges of both the Desk and Back.

NOTE: If the Panel Bed is slightly too heavy too open and close without the Studio Desk/Table mounted, you should add one Spring to the right and to the left to assist in balance. An odd number of Springs right and left may be used to get balance.

STEP 2: Assemble Desk Top and Back to the Brackets.

1. Assemble the Desk/Table with the Upper Brackets as shown in Drawing #1.
2. Screw the Desk Top first to the Left and Right Brackets. This provides a seat for the Back.
3. Attach the Desk Back to the back bracket. Be sure of alignment and then screw the Desk and Back together from the bottom side with the #8x40mm Screws provided.
4. Mount the Hinges to the Back as shown in Drawing #2.

Drawing #1: Upper Bracket

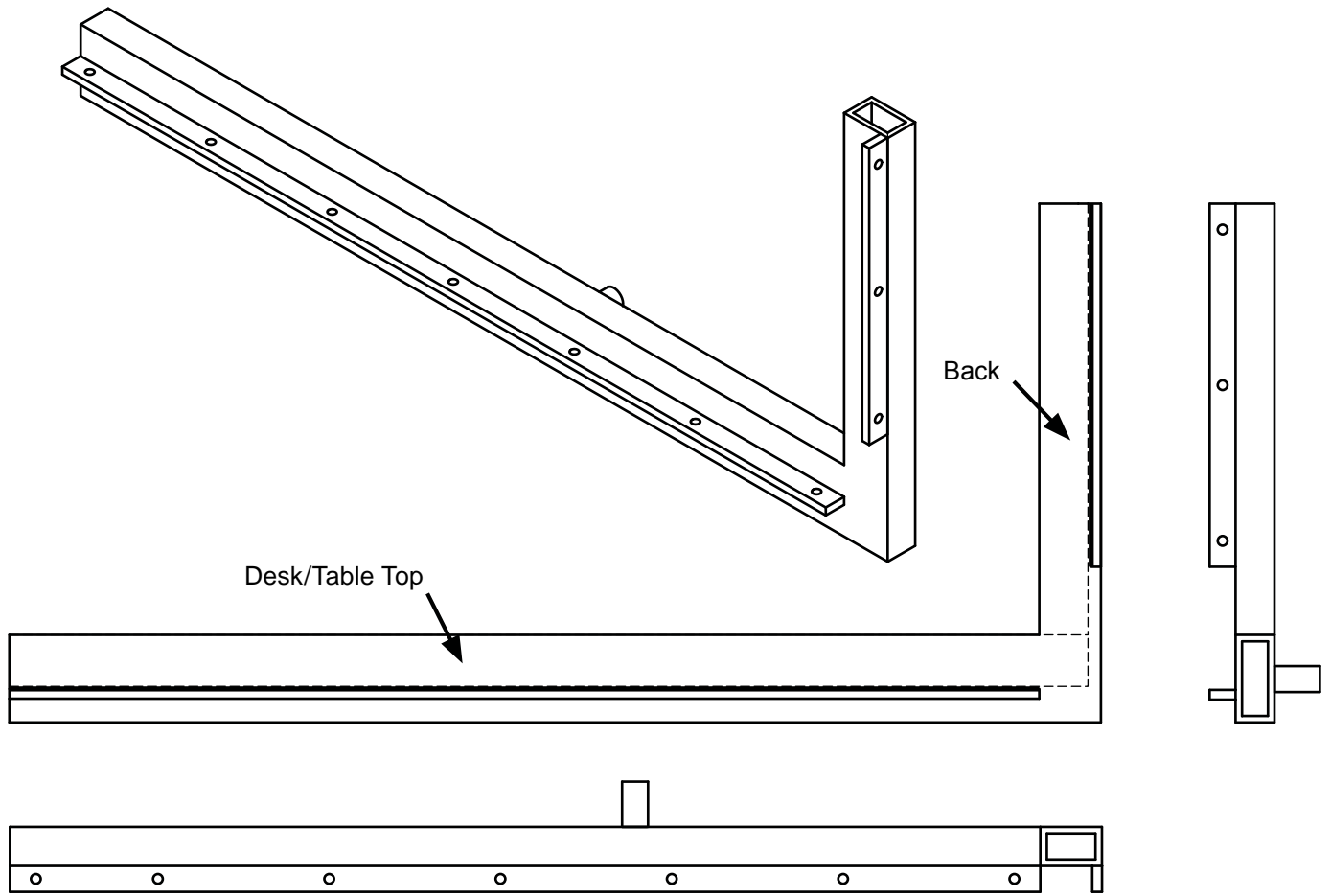

Drawing #2: Hinges to Back

The short Hinge leaf attaches to the Back, the long Hinge leaf attaches to the Bed Face

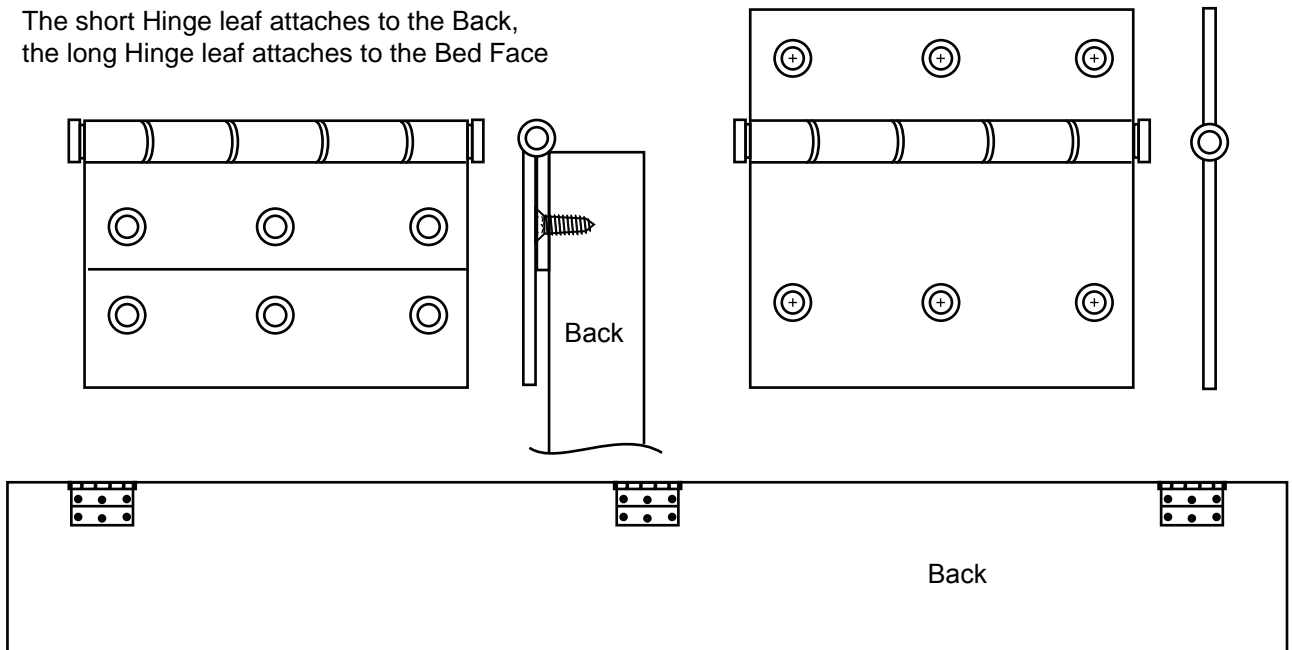

STEP 3: Install Pivot Brackets and Desk Leg Packers

1. Install the left and right Pivot Brackets as shown in Drawing #3. Insert Desk Packers between pivot bracket and end panel of the cabinetry. This will square up the legs with the cabinetry.
2. Mount the Brackets exactly 25mm inside of the Cabinet vertical. The pivot point (standoff) must face outward to allow the Leg to line up with the vertical edge of the Panel.

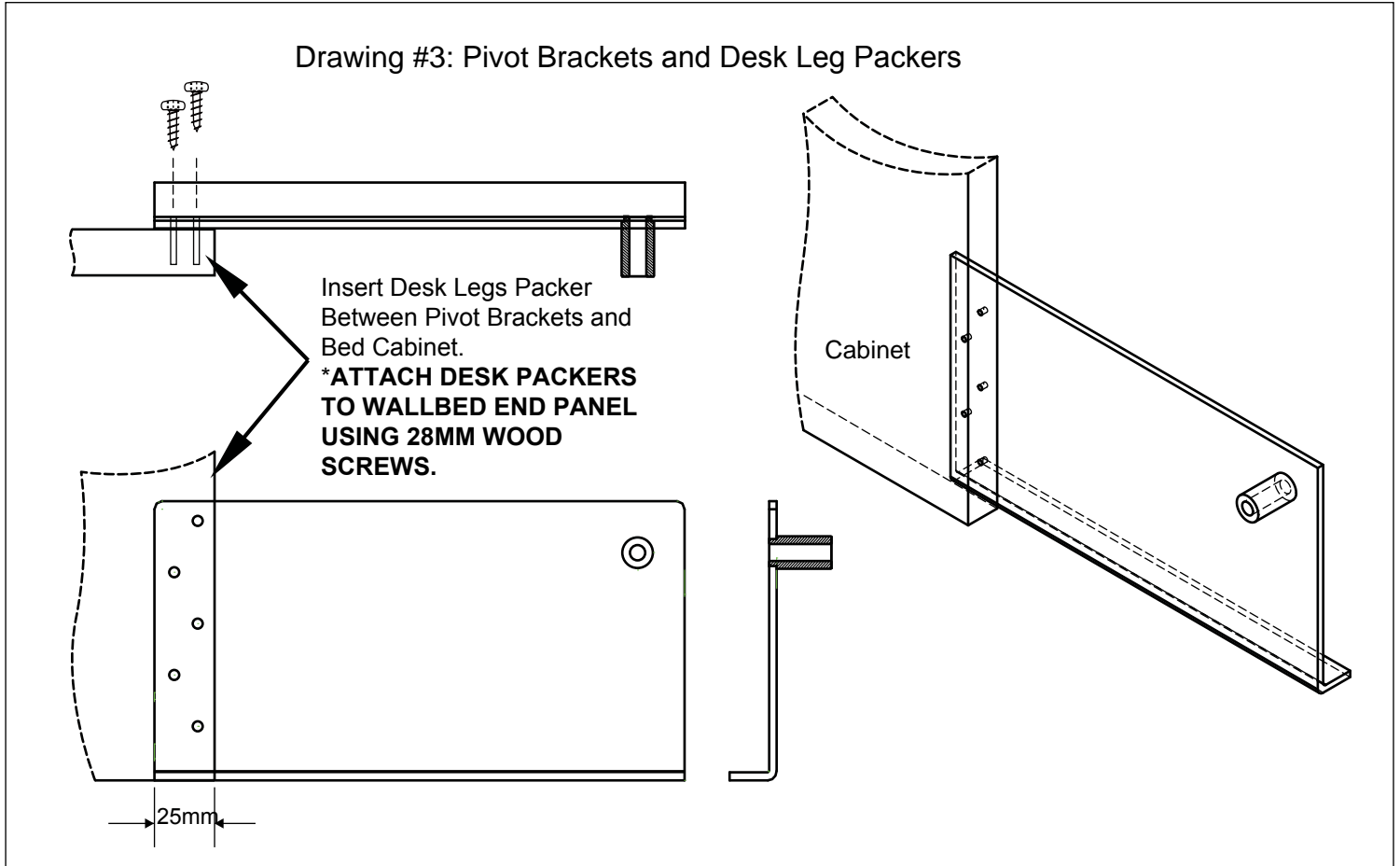

STEP 4: Assemble Desk/Table to Bed Face

1. Assemble the Desk/Table on the floor where it will be located when it is in use (Drawing #4).
2. Hand tighten the Bolts as the Legs needs to be detached later to mount the Desk to the Bed Face.

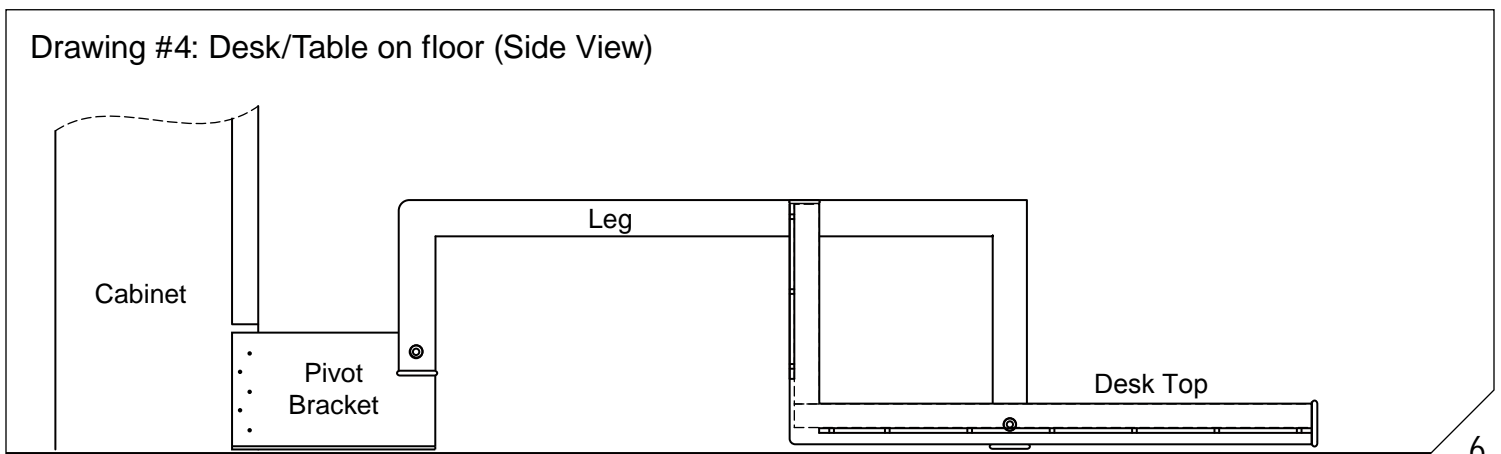

STEP 5: Install Desk/Table to Bed Face Panel

1. Raise the Desk and hold it in the UP position (where it will be when mounted to the Bed Face).
2. Hold the Desk against the Bed Face, making sure that the Desk is level both front to back and end to end.
3. Using a pencil, lightly mark the Hinge locations and heights on the Bed Face Panel. Mark the height of the top edge of the Back.
4. Lower the Desk to the floor and detach the Legs from the Pivot Brackets.
5. Mount the Hinge Mate Clips to the Bed Face to assist in mounting and leveling the desk. Attach the Clips so the clip shelves are 38mm below the pencil mark of the top edge of the Back. Check the level line between all three Clips to ensure that the desk will be level. Secure all three Hinge Clips. See Drawing #5.
6. Bring the Studio Desk/Table back up to the Bed Face and place the long Hinge leaves in the Hinge Clips. Screw the long leaves of the Hinges to the Bed Face. Recheck levelness in all directions.
7. Re-attach the Legs and snug up both upper and lower pivots. It is not necessary to remove Hinge Clips as they are out of sight after the installation.

Drawing #5: Hinge Clips

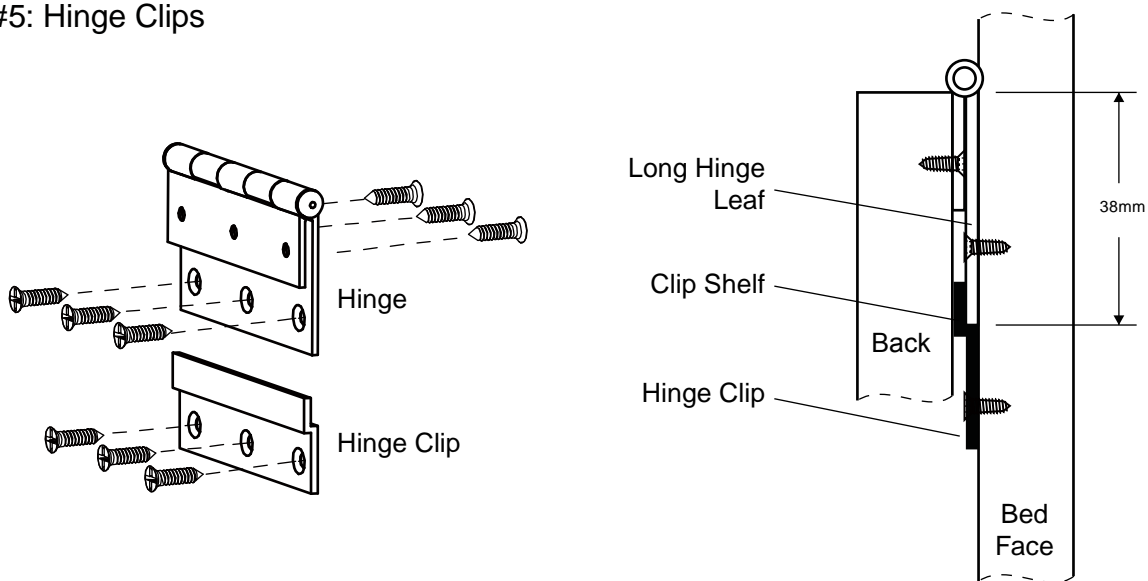

STEP 6: Test

1. Operate the Desk/Table slowly.
2. Double check the levels.
3. Make sure that all End Caps are installed.



Alpha Studio Desk Cut Size				
	Desk		Back	
Single	1/1056x560	2L	1/1056x216	2L
Double	1/1435x560	2L	1/1435x216	2L
Queen	1/1588x560	2L	1/1588x216	2L
King	1/1996x560	2L	1/1996x216	2L